

Request For Quotation

Order the parts you need from our real-time inventory database. Simply complete a request for quotation form with your part information and a sales representative will respond to you with price and availability.

[Request For Quotation](#)

Your free datasheet starts on the next page.

More datasheets and data books are available from our homepage: <http://www.datasheetarchive.com>

LOW-POWER MONOSTABLE/ASTABLE MULTIVIBRATOR

- LOW POWER CONSUMPTION : SPECIAL COS/MOS OSCILLATOR CONFIGURATION
- MONOSTABLE (one-shot) OR ASTABLE (free-running) OPERATION
- TRUE AND COMPLEMENTED BUFFERED OUTPUTS
- ONLY ONE EXTERNAL R AND C REQUIRED
- BUFFERED INPUTS
- QUIESCENT CURRENT SPECIFIED TO 20V FOR HCC DEVICE
- STANDARDIZED, SYMMETRICAL OUTPUT CHARACTERISTICS
- 5V, 10V, AND 15V PARAMETRIC RATINGS
- INPUT CURRENT OF 100nA AT 18V AND 25°C FOR HCC DEVICE
- 100% TESTED FOR QUIESCENT CURRENT
- MEETS ALL REQUIREMENTS OF JEDEC TENTATIVE STANDARD N° 13A, "STANDARD SPECIFICATIONS FOR DESCRIPTION OF "B" SERIES CMOS DEVICES"

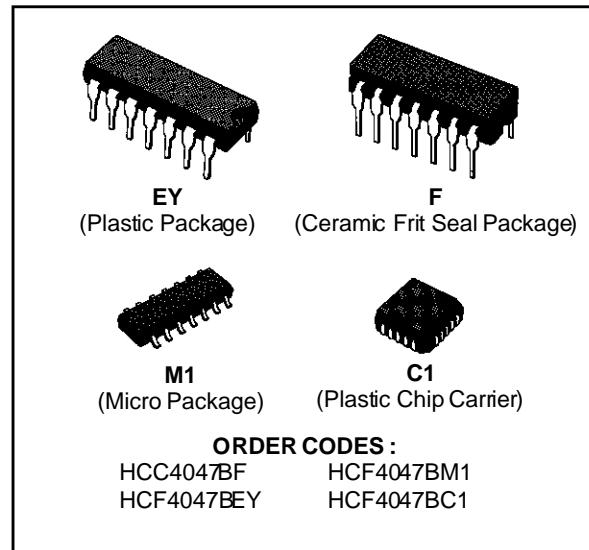

DESCRIPTION

The **HCC4047B** (extended temperature range) and **HCF4047B** (intermediate temperature range) are monolithic integrated circuits, available in 14-lead dual in-line plastic or ceramic package and plastic micropackage. The **HCC/HCF4047B** consists of a gatable astable multivibrator with logic techniques incorporated to permit positive or negative edge-triggered monostable multivibrator action with retriggering and external counting options. Inputs include +TRIGGER -TRIGGER, ASTABLE, ASTABLE, RE-TRIGGER, and EXTERNAL RESET. Buffered outputs are Q, \bar{Q} , and OSCILLATOR. In all modes of operation, an external capacitor must be connected between C-Timing and RC-Common terminals, and an external resistor must be connected between the R-Timing and RC-Common terminals. For operating modes see functional terminal connections and application notes.

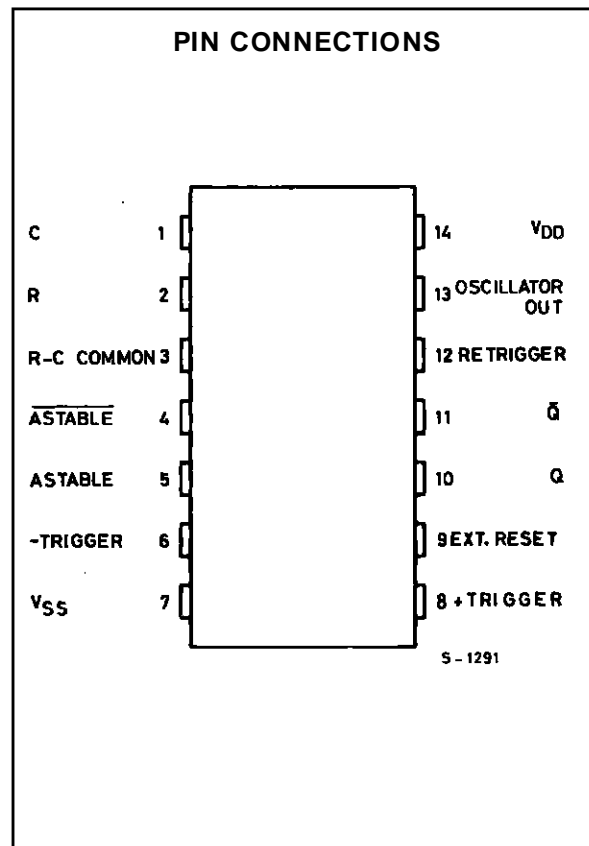

HCC/HCF4047B

BLOCK DIAGRAM

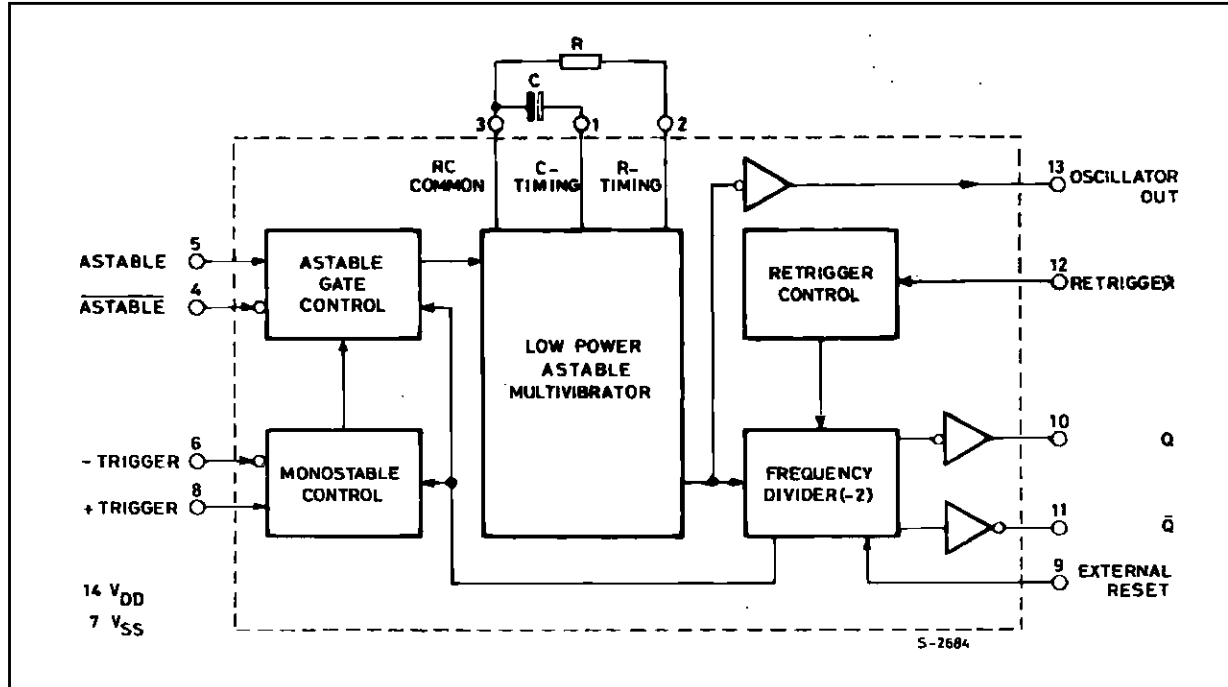

FUNCTIONAL TERMINAL CONNECTIONS

Function*	Terminal Connections			Output Pulse From	Output Period or Pulse Width
	to V _{DD}	to V _{SS}	Input Pulse to		
Astable Multivibrator :					
Free Running	4, 5, 6, 14	7, 8, 9, 12	—	10, 11, 13	$t_A(10, 11) = 4.40RC$
True Gating	4, 6, 14	7, 8, 9, 12	5	10, 11, 13	
Complement Gating	6, 14	5, 7, 8, 9, 12	4	10, 11, 13	$t_A(13) = 2.20RC$
Monostable Multivibrator :					
Positive-Edge Trigger	4, 14	5, 6, 7, 9, 12	8	10, 11	
Negative-Edge Trigger	4, 8, 14	5, 7, 9, 12	6	10, 11	
Retriggerable	4, 14	5, 6, 7, 9	8, 12	10, 11	
External Countdown**	14	5, 6, 7, 8, 9, 12	—	10, 11	$t_M(10, 11) = 2.48RC$

* In all cases external capacitor and resistor between pins, 1, 2 and 3 (see logic diagrams).

** Input pulse to Reset of External Counting Chip.
External Counting Chip Output to pin 4.

ABSOLUTE MAXIMUM RATINGS

Symbol	Parameter	Value	Unit
V _{DD} *	Supply Voltage : HCC Types	- 0.5 to + 20	V
	HCF Types	- 0.5 to + 18	V
V _i	Input Voltage	- 0.5 to V _{DD} + 0.5	V
I _I	DC Input Current (any one input)	± 10	mA
P _{tot}	Total Power Dissipation (per package)	200	mW
	Dissipation per Output Transistor for T _{op} = Full Package-temperature Range	100	mW
T _{op}	Operating Temperature : HCC Types	- 55 to + 125	°C
	HCF Types	- 40 to + 85	°C
T _{stg}	Storage Temperature	- 65 to + 150	°C

Stresses above those listed under "Absolute Maximum Ratings" may cause permanent damage to the device. This is a stress rating only and functional operation of the device at these or any other conditions above those indicated in the operational sections of this specification is not implied. Exposure to absolute maximum rating conditions for external periods may affect device reliability.

* All voltage values are referred to V_{SS} pin voltage.

RECOMMENDED OPERATING CONDITIONS

Symbol	Parameter	Value	Unit
V _{DD}	Supply Voltage : HCC Types	3 to 18	V
	HCF Types	3 to 15	V
V _I	Input Voltage	0 to V _{DD}	V
T _{op}	Operating Temperature : HCC Types	- 55 to + 125	°C
	HCF Types	- 40 to + 85	°C

LOGIC DIAGRAM

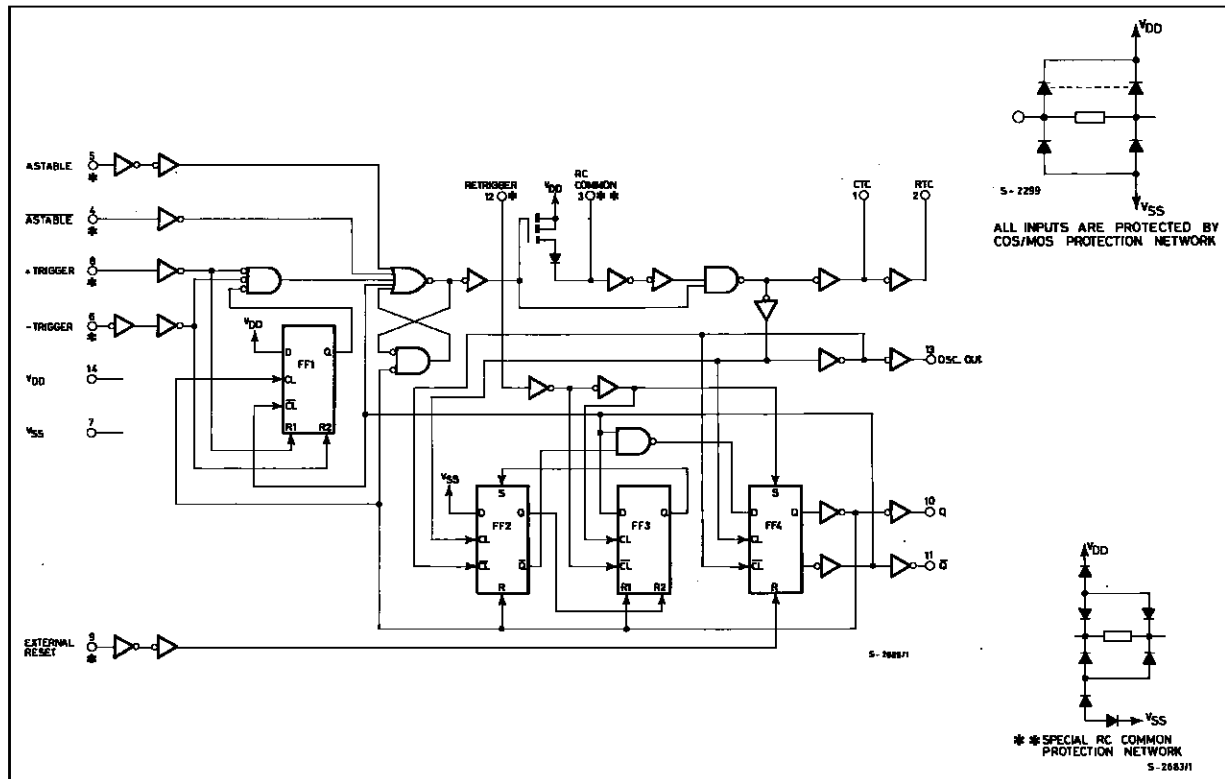

HCC/HCF4047B

Detail for Flip-flops FF1 and FF3 (a) and for Flip-flops FF2 and FF4 (b).

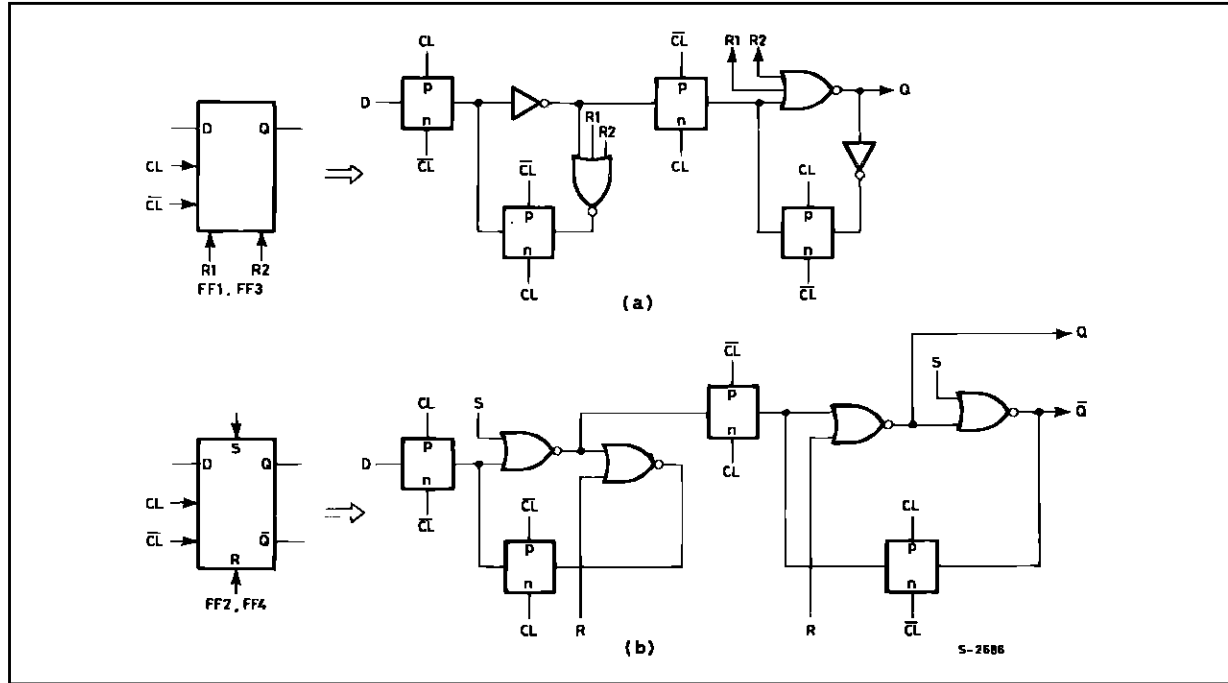

STATIC ELECTRICAL CHARACTERISTICS (over recommended operating conditions)

Symbol	Parameter	Test Conditions				Value						Unit					
		V _I (V)	V _O (V)	I _o (μA)	V _{DD} (V)	T _{Low} *		25°C			T _{High} *						
						Min.	Max.	Min.	Typ.	Max.	Min.		Max.				
I _L	Quiescent Current				5	T _{Low} *		25°C			T _{High} *		μA				
						HCC Types	0/ 5				1			0.02	1		30
							0/10			10	2			0.02	2		60
						HCC Types	0/15			15	4			0.02	4		120
							0/20			20	20			0.04	20		600
						HCF Types	0/ 5			5	4			0.02	4		30
0/10			10	8			0.02	8		60							
0/15			15	16			0.02	16		120							
V _{OH}	Output High Voltage			< 1	5	T _{Low} *		25°C			T _{High} *		V				
						HCC Types	0/ 5			4.95				4.95			
							0/10			10	9.95			9.95		9.95	
HCC Types	0/15			15	14.95		14.95		14.95								
	HCF Types	5/0		< 1	5		0.05		0.05		0.05						
10/0			< 1	10		0.05		0.05		0.05							
15/0			< 1	15		0.05		0.05		0.05							
V _{IH}	Input High Voltage			< 1	5	T _{Low} *		25°C			T _{High} *		V				
						HCC Types	0.5/4.5			3.5		3.5			3.5		
							1/9			10	7			7		7	
HCF Types	1.5/13.5		< 1	15	11		11		11								

* T_{Low} = - 55°C for HCC device : - 40°C for HCF device.

* T_{High} = + 125°C for HCC device : + 85°C for HCF device.

The Noise Margin for both "1" and "0" level is : 1V min. with V_{DD} = 5V, 2V min. with V_{DD} = 10V, 2.5V min. with V_{DD} = 15V.

STATIC ELECTRICAL CHARACTERISTICS (continued)

Symbol	Parameter		Test Conditions				Value						Unit	
			V _I (V)	V _O (V)	I _O (μ A)	V _{DD} (V)	T _{Low} *		25°C			T _{High} *		
							Min.	Max.	Min.	Typ.	Max.	Min.		Max.
V _{IL}	Input Low Voltage		4.5/0.5	< 1	5		1.5			1.5		1.5	V	
			9/1	< 1	10		3			3		3		
			13.5/1.5	< 1	15		4			4		4		
I _{OH}	Output Drive Current	HCC Types	0/ 5	2.5		5	- 2		- 1.6	- 3.2		- 1.15	mA	
			0/ 5	4.6		5	- 0.64		- 0.51	- 1		- 0.36		
			0/10	9.5		10	- 1.6		- 1.3	- 2.6		- 0.9		
			0/15	13.5		15	- 4.2		- 3.4	- 6.8		- 2.4		
		HCF Types	0/ 5	2.5		5	- 1.53		- 1.36	- 3.2		- 1.1		
			0/ 5	4.6		5	- 0.52		- 0.44	- 1		- 0.36		
			0/10	9.5		10	- 1.3		- 1.1	- 2.6		- 0.9		
			0/15	13.5		15	- 3.6		- 3.0	- 6.8		- 2.4		
I _{OL}	Output Sink Current	HCC Types	0/ 5	0.4		5	0.64		0.51	1		0.36	mA	
			0/10	0.5		10	1.6		1.3	2.6		0.9		
			0/15	1.5		15	4.2		3.4	6.8		2.4		
		HCF Types	0/ 5	0.4		5	0.52		0.44	1		0.36		
			0/10	0.5		10	1.3		1.1	2.6		0.9		
			0/15	1.5		15	3.6		3.0	6.8		2.4		
I _{IH} , I _{IL}	Input leakage Current	HCC Types	0/18	Any Input		18		± 0.1		$\pm 10^{-5}$	± 0.1		± 1	
		HCF Types	0/15	Any Input		15		± 0.3		$\pm 10^{-5}$	± 0.3		± 1	
C _I	Input Capacitance		Any Input						5	7.5		pF		

* T_{Low} = - 55°C for HCC device : - 40°C for HCF device.* T_{High} = + 125°C for HCC device : + 85°C for HCF device.The Noise Margin for both "1" and "0" level is : 1V min. with V_{DD} = 5V, 2V min. with V_{DD} = 10V, 2.5V min. with V_{DD} = 15V.DYNAMIC ELECTRICAL CHARACTERISTICS (T_{amb} = 25°C, C_L = 50pF, R_L = 200k Ω , typical temperature coefficient for all V_{DD} values is 0.3%/°C, all input rise and fall times = 20ns)

Symbol	Parameter		Test Conditions		Value			Unit
				V _{DD} (V)	Min.	Typ.	Max.	
t _{PLH} , t _{PHL}	Propagation Delay Time	Astable, $\overline{\text{Astable}}$ to osc. out		5		200	400	ns
				10		100	200	
				15		80	160	
		Astable, $\overline{\text{Astable}}$ to Q, $\overline{\text{Q}}$		5		350	700	
				10		175	350	
				15		125	250	
		+ or - Trigger to Q, $\overline{\text{Q}}$		5		500	1000	
				10		225	450	
				15		150	300	

HCC/HCF4047B

DYNAMIC ELECTRICAL CHARACTERISTICS (continued)

Symbol	Parameter		Test Conditions		Value			Unit
				V _{DD} (V)	Min.	Typ.	Max.	
t _{PLH} , t _{PHL}	Propagation Delay Time	Retrigger to Q, \bar{Q}		5		300	600	ns
				10		150	300	
				15		100	200	
		External Reset to Q, \bar{Q}		5		250	500	
				10		100	200	
				15		70	140	
t _{THL} , t _{TLH}	Transition Time Osc. Out Q, \bar{Q}		5		100	200	ns	
			10		50	100		
			15		40	80		
t _w	Input Pulse Width :	+ Trigger, - Trigger		5		200	400	ns
				10		80	160	
				15		50	100	
		Reset		5		100	200	
				10		50	100	
				15		30	60	
		Retrigger		5		300	600	
				10		115	230	
				15		75	150	
t _r , t _f	Input Rise and Fall Time All Inputs		5	Unlimited			μs	
			10					
			15					
	Q or \bar{Q} Deviation from 50% Duty Factor		5		± 0.5	± 1	%	
			10		± 0.5	± 1		
			15		± 0.1	± 0.5		

Typical Output Low (sink) Current Characteristics.

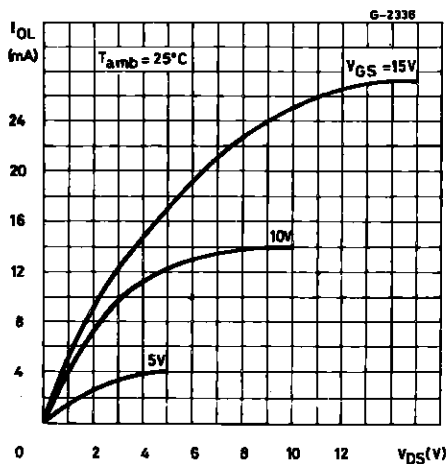

Minimum Output Low (sink) Current Characteristics.

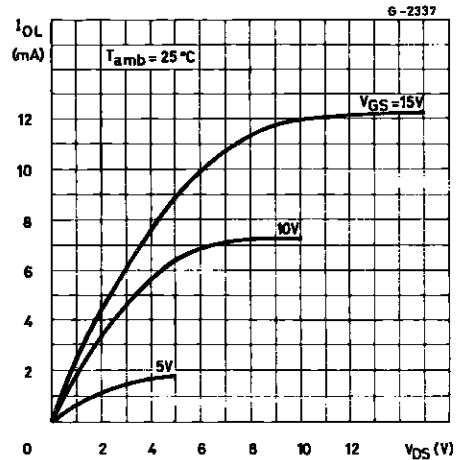

Typical Output High (source) Current Characteristics.

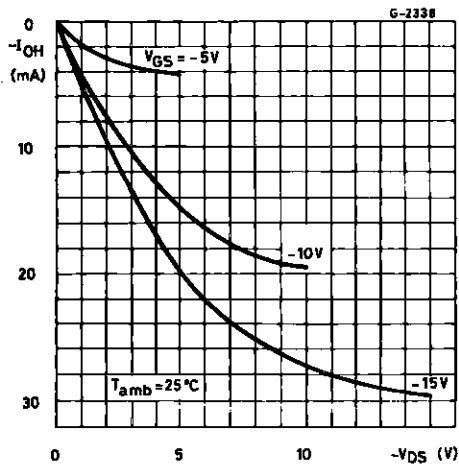

Minimum Output High (source) Current Characteristics.

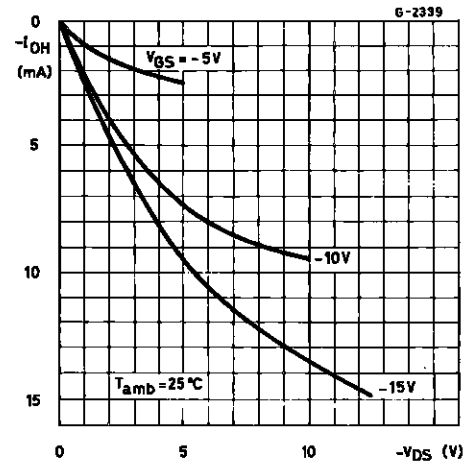

APPLICATION INFORMATION

1 - CIRCUIT DESCRIPTION

Astable operation is enabled by a high level on the **ASTABLE** input. The period of the square wave at the Q and \bar{Q} Outputs in this mode of operation is a function of the external components employed. "True" input pulses on the **ASTABLE** input or "Complement" pulses on the **ASTABLE** input allow the circuit to be used as a gatable multivibrator. The **OSCILLATOR** output period will be half of the Q terminal output in the astable mode. However, a 50% duty cycle is not guaranteed at this output. In the monostable mode, positive-edge triggering is accomplished by application of a leading-edge pulse to the **+TRIGGER** input and a low level to the **-TRIGGER** input. For negative-edge triggering, a trailing-edge pulse is applied to the **-TRIGGER** and a high level is applied to the **+TRIGGER**. Input pulses may be of any duration relative to the output pulse. The multivibrator can be retriggered (on the leading edge only) by applying a common pulse to both the **RETRIGGER** and **+TRIGGER** inputs. In this mode

the output pulse remains high as long as the input pulse period is shorter than the period determined by the RC components. An external countdown option can be implemented by coupling "Q" to an external "N" counter and resetting the counter with the trigger pulse. The counter output pulse is fed back to the **ASTABLE** input and has a duration equal to N times the period of the multivibrator. A high level on the **EXTERNAL RESET** input assures no output pulse during an "ON" power condition. This input can also be activated to terminate the output pulse at any time. In the monostable mode, a high-level or power-on reset pulse, must be applied to the **EXTERNAL RESET** whenever V_{DD} is applied.

2 - ASTABLE MODE

The following analysis presents worst-case variations from unit-to-unit as a function of transfer-voltage (V_{TR}) shift (33% – 67% V_{DD}) for free-running (astable) operation.

HCC/HCF4047B

ASTABLE MODE WAVEFORMS.

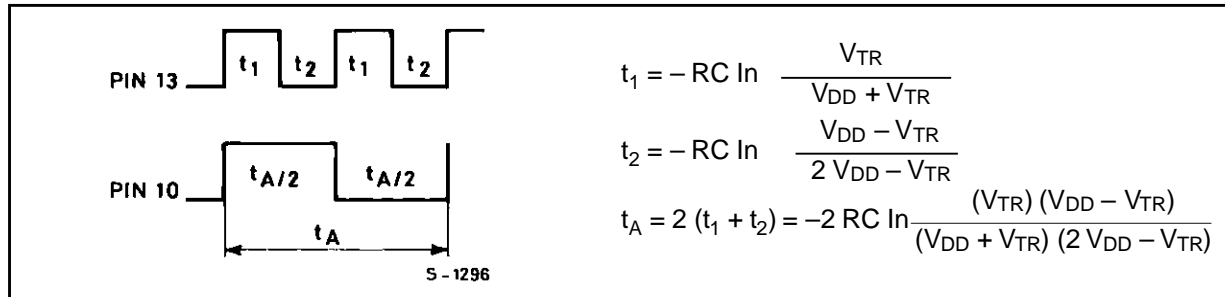

Typ : $V_{TR} = 0.5 V_{DD}$ $t_A = 4.40 RC$

Min : $V_{TR} = 0.33 V_{DD}$ $t_A = 4.62 RC$

Max : $V_{TR} = 0.67 V_{DD}$ $t_A = 4.62 RC$

thus if $t_A = 4.40 RC$ is used, the maximum variation will be (+ 5.0%, - 0.0%)

In addition to variations from unit-to-unit, the astable

period may vary as a function of frequency with respect to V_{DD} and temperature.

3 - MONOSTABLE MODE

The following analysis presents worst-case variations from unit-to-unit as a function of transfer-voltage (V_{TR}) shift (33% - 67% V_{DD}) for one-shot (monostable) operation.

MONOSTABLE WAVEFORMS.

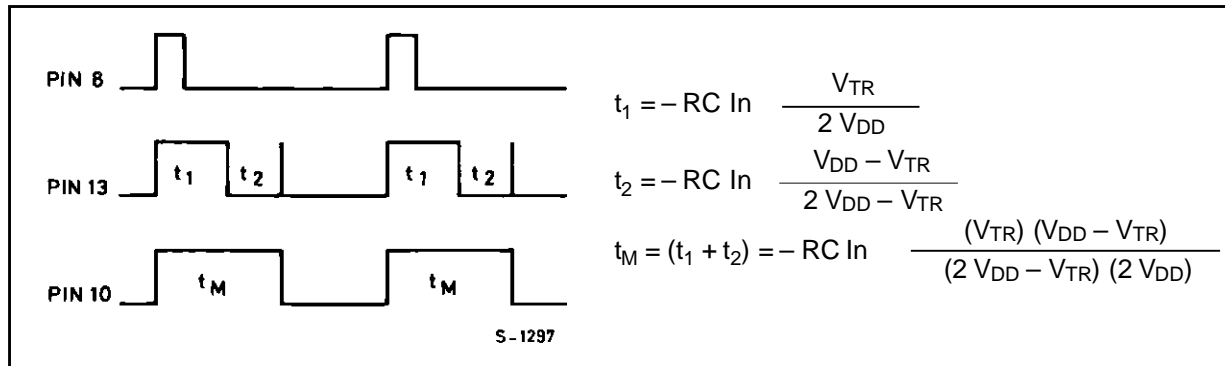

Where t_M = monostable mode pulse width. Values for t_M are as follows :

Typ : $V_{TR} = 0.5 V_{DD}$ $t_M = 2.48 RC$

Min : $V_{TR} = 0.33 V_{DD}$ $t_M = 2.71 RC$

Max : $V_{TR} = 0.67 V_{DD}$ $t_M = 2.48 RC$

Thus if $t_M = 2.48 RC$ is used, the maximum variation will be (+ 9.3%, - 0.0%).

Note : In the astable mode, the first positive half cycle has a duration of T_M ; succeeding durations are $t_A/2$.

In addition to variations from unit to unit, the monostable pulse width may vary as a function of frequency with respect to V_{DD} and temperature.

mode to extend the output-pulse duration, or to compare the frequency of an input signal with that of the internal oscillator. In the retrigger mode the input pulse is applied to terminals 8 and 12, and the output is taken from terminal 10 or 11. As shown in fig. A normal monostable action is obtained when one retrigger pulse is applied. Extended pulse duration is obtained when more than one pulse is applied. For two input pulses, $t_{RE} = t_1' + t_1 + 2t_2$. For more than two pulses, t_{RE} (Q OUTPUT) terminates at some variable time t_D after the termination of the last retrigger pulse. t_D is variable because t_{RE} (Q OUTPUT) terminates after the second positive edge of the oscillator output appears at flip-flop 4 (see logic diagram).

4 - RETRIGGER MODE

The **HCC/HCF4047B** can be used in the retrigger

Figure A : Retrigger-mode Waveforms.

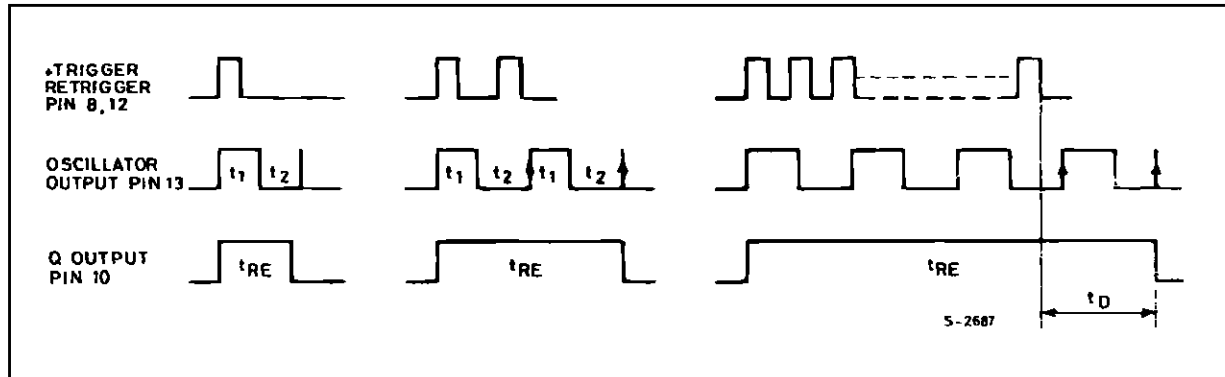

5 - EXTERNAL COUNTER OPTION

Time t_M can be extended by any amount with the use of external counting circuitry. Advantages include digitally controlled pulse duration, small timing capacitors for long time periods, and extremely fast recovery time.

A typical implementation is shown in fig. B. The pulse duration at the output is

$$t_{ext} = (N - 1) (t_A) + (t_M + t_A/2)$$

Where t_{ext} = pulse duration of the circuitry, and N is the number of counts used.

Figure B : Implementation of External Counter Option.

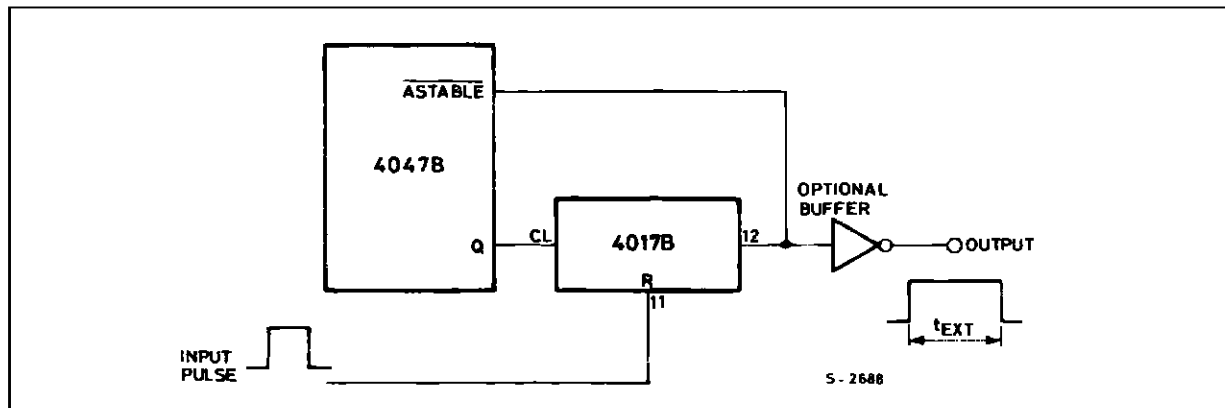

6 - POWER CONSUMPTION

In the standby mode (Monostable or Astable), power dissipation will be a function of leakage current in the circuit, as shown in the static electrical characteristics. For dynamic operation, the power needed to charge the external timing capacitor C is given by the following formula :

Astable Mode : $P = 2CV^2f$. (Output at Pin 13)

$P = 4CV^2f$. (Output at Pin 10 and 11)

Monostable Mode : $P = \frac{(2.9CV^2) (\text{Duty Cycle})}{T}$

(Output at Pin 10 and 11)

The circuit is designed so that most of the total power is consumed in the external components. In practice, the lower the values of frequency and volt-

age used, the closer the actual power dissipation will be to the calculated value.

Because the power dissipation does not depend on R, a design for minimum power dissipation would be a small value of C. The value of R would depend on the desired period (within the limitations discussed above).

7 - TIMING-COMPONENT LIMITATIONS

The capacitor used in the circuit should be non-polarized and have low leakage (i.e. the parallel resistance of the capacitor should be an order of magnitude greater than the external resistor used). There is no upper or lower limit for either R or C value to maintain oscillation.

However, in consideration of accuracy, C must be much larger than the inherent stray capacitance in

HCC/HCF4047B

the system (unless this capacitance can be measured and taken into account). R must be much larger than the COS/MOS "ON" resistance in series with it, which typically is hundreds of ohms. In addition, with very large values of R, some short-term instability with respect to time may be noted.

The recommended values for these components to maintain agreement with previously calculated formulas without trimming should be :

$C \geq 100\text{pF}$, up to any practical value, for astable modes ;

$C \geq 1000\text{pF}$, up to any practical value, for mono-stable modes.

$10\text{K}\Omega \leq R \leq 1\text{M}\Omega$.

TEST CIRCUITS

Quiescent Device Current.

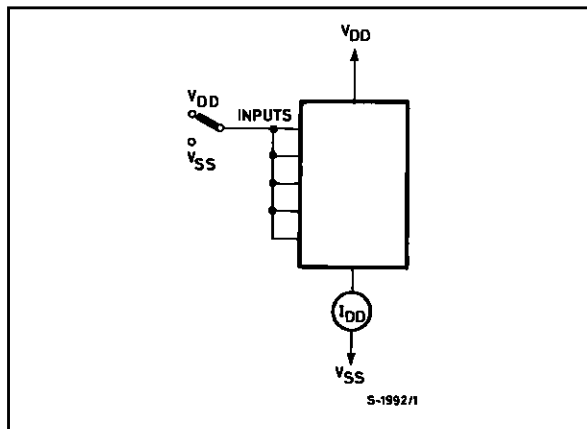

Input Voltage.

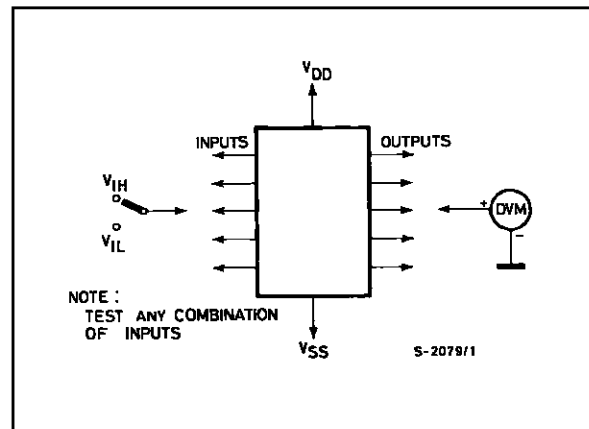

Input Current.

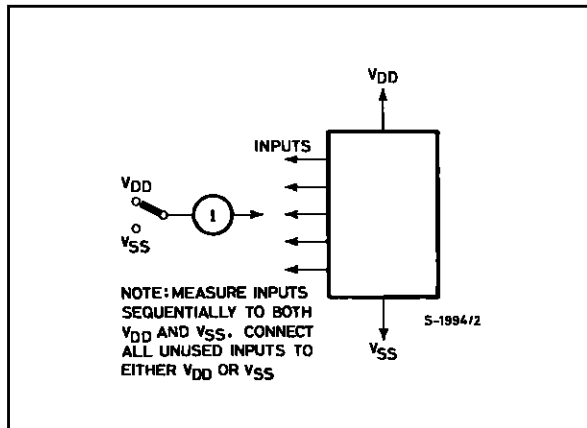

Plastic DIP14 MECHANICAL DATA

DIM.	mm			inch		
	MIN.	TYP.	MAX.	MIN.	TYP.	MAX.
a1	0.51			0.020		
B	1.39		1.65	0.055		0.065
b		0.5			0.020	
b1		0.25			0.010	
D			20			0.787
E		8.5			0.335	
e		2.54			0.100	
e3		15.24			0.600	
F			7.1			0.280
I			5.1			0.201
L		3.3			0.130	
Z	1.27		2.54	0.050		0.100

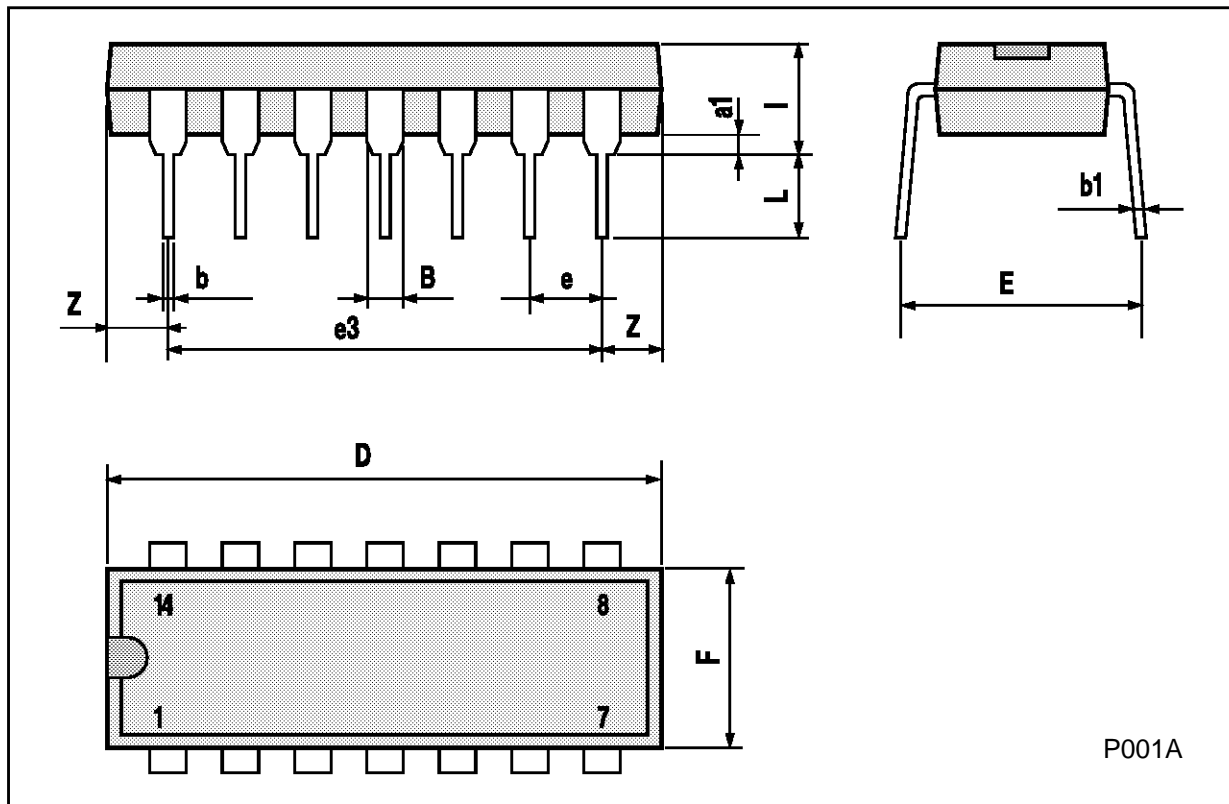

Ceramic DIP14/1 MECHANICAL DATA

DIM.	mm			inch		
	MIN.	TYP.	MAX.	MIN.	TYP.	MAX.
A			20			0.787
B			7.0			0.276
D		3.3			0.130	
E	0.38			0.015		
e3		15.24			0.600	
F	2.29		2.79	0.090		0.110
G	0.4		0.55	0.016		0.022
H	1.17		1.52	0.046		0.060
L	0.22		0.31	0.009		0.012
M	1.52		2.54	0.060		0.100
N			10.3			0.406
P	7.8		8.05	0.307		0.317
Q			5.08			0.200

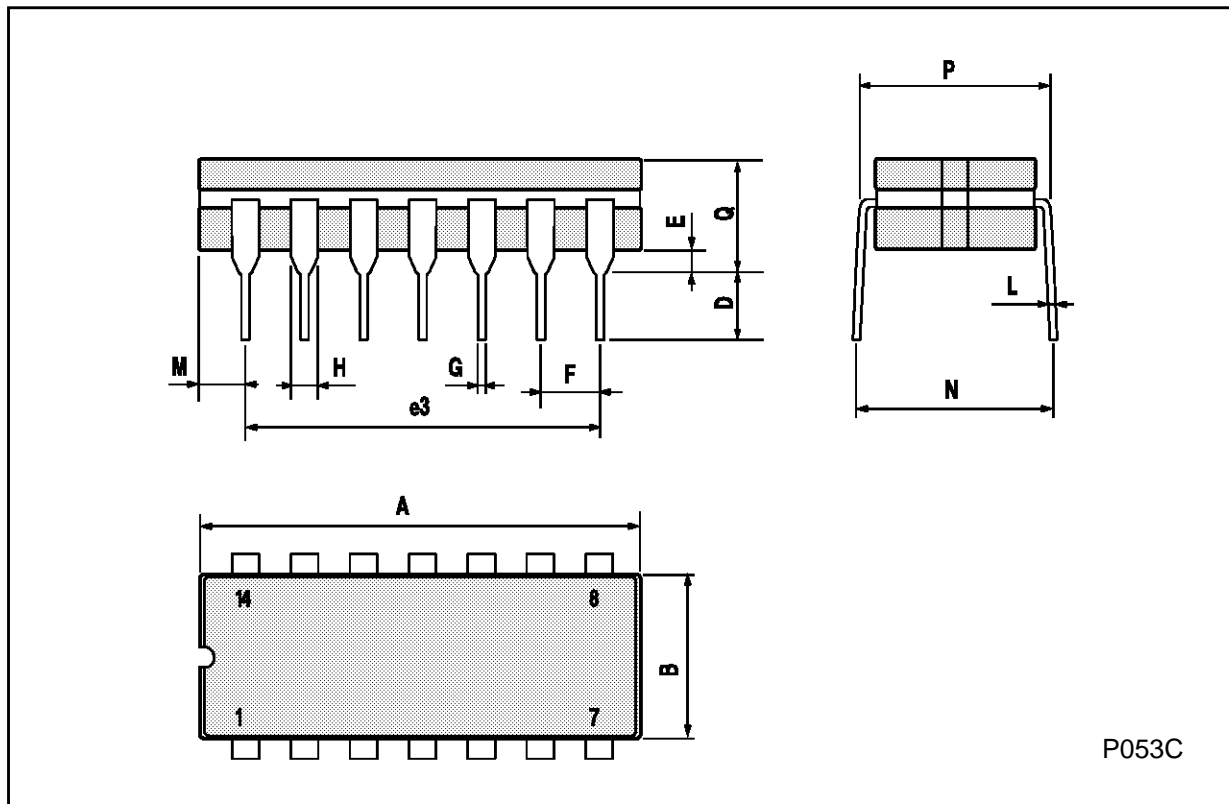

P053C

SO14 MECHANICAL DATA

DIM.	mm			inch		
	MIN.	TYP.	MAX.	MIN.	TYP.	MAX.
A			1.75			0.068
a1	0.1		0.2	0.003		0.007
a2			1.65			0.064
b	0.35		0.46	0.013		0.018
b1	0.19		0.25	0.007		0.010
C		0.5			0.019	
c1	45° (typ.)					
D	8.55		8.75	0.336		0.344
E	5.8		6.2	0.228		0.244
e		1.27			0.050	
e3		7.62			0.300	
F	3.8		4.0	0.149		0.157
G	4.6		5.3	0.181		0.208
L	0.5		1.27	0.019		0.050
M			0.68			0.026
S	8° (max.)					

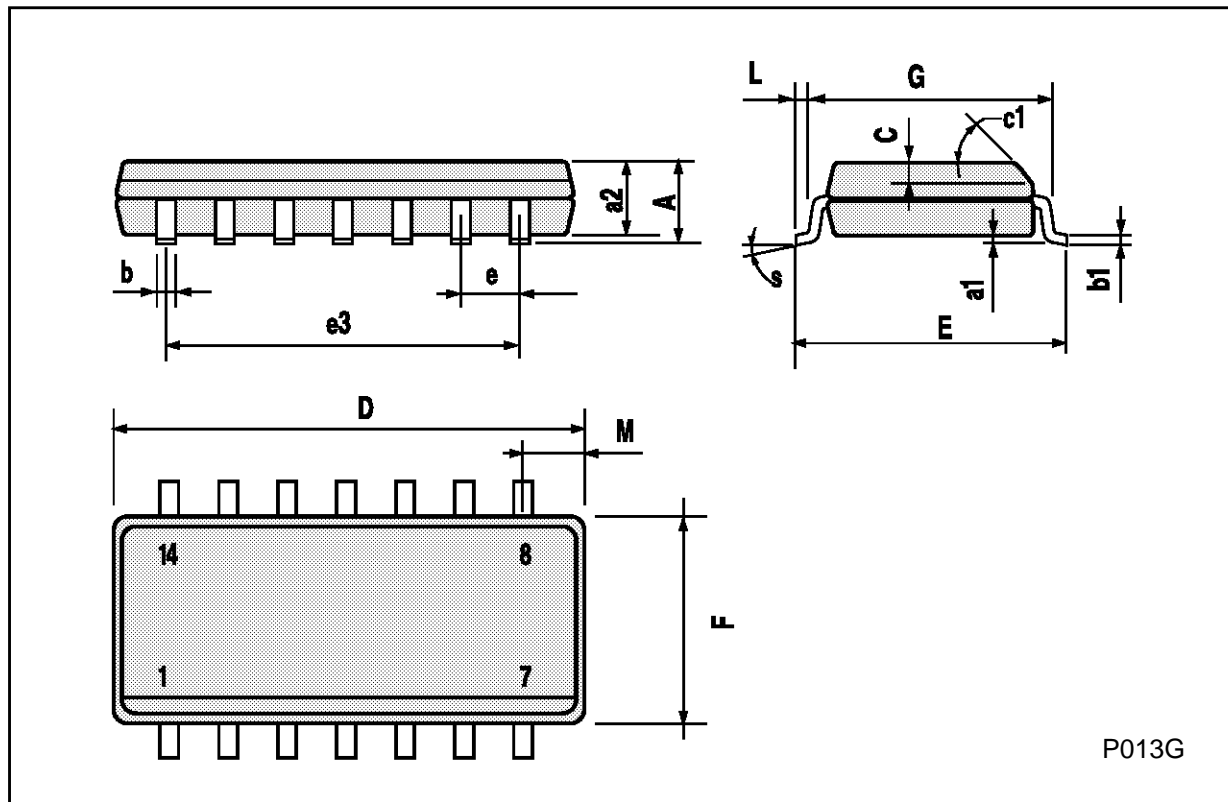

PLCC20 MECHANICAL DATA

DIM.	mm			inch		
	MIN.	TYP.	MAX.	MIN.	TYP.	MAX.
A	9.78		10.03	0.385		0.395
B	8.89		9.04	0.350		0.356
D	4.2		4.57	0.165		0.180
d1		2.54			0.100	
d2		0.56			0.022	
E	7.37		8.38	0.290		0.330
e		1.27			0.050	
e3		5.08			0.200	
F		0.38			0.015	
G			0.101			0.004
M		1.27			0.050	
M1		1.14			0.045	

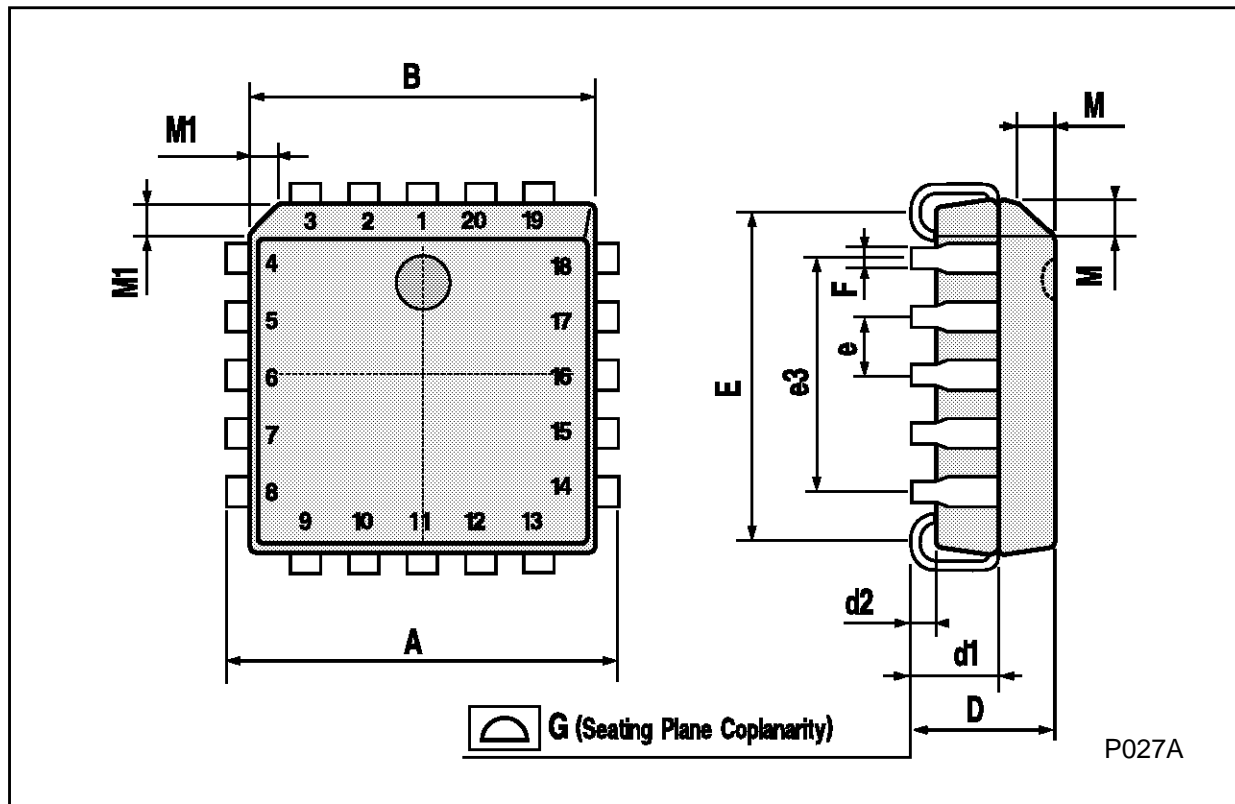

Information furnished is believed to be accurate and reliable. However, SGS-THOMSON Microelectronics assumes no responsibility for the consequences of use of such information nor for any infringement of patents or other rights of third parties which may result from its use. No license is granted by implication or otherwise under any patent or patent rights of SGS-THOMSON Microelectronics. Specifications mentioned in this publication are subject to change without notice. This publication supersedes and replaces all information previously supplied. SGS-THOMSON Microelectronics products are not authorized for use as critical components in life support devices or systems without express written approval of SGS-THOMSON Microelectronics.

© 1994 SGS-THOMSON Microelectronics - All Rights Reserved

SGS-THOMSON Microelectronics GROUP OF COMPANIES

Australia - Brazil - France - Germany - Hong Kong - Italy - Japan - Korea - Malaysia - Malta - Morocco - The Netherlands -
Singapore - Spain - Sweden - Switzerland - Taiwan - Thailand - United Kingdom - U.S.A